



BURLODGE

United Kingdom

Italy

France

U.S.A.

Canada



RTS

READY TO SERVE

SYSTEM
TO TRANSPORT
AND DISTRIBUTE
PERSONALIZED
MEAL TRAYS

Standard HACCP
Cook Serve



**RTS: DESIGN,
EFFICIENCY
AND PERFORMANCE**

READY TO SERVE



When you demand hot and cold food to be served to your clients, Ready To Serve (RTS) is the answer.

The Ready To Serve supports hot line preparation of trays and provides an effective way to transport and distribute hot and cold meals.

The RTS helps your staff to get ready to serve excellent meals at the right temperatures while using ergonomically safe equipment that is flexible in application and simple to operate.

The Ready To Serve Burlodge Manufacturing Excellence Continues.

The RTS is constructed using a combination of 304, 18/10 stainless steel and aluminum, making it strong and durable as well as easy to move throughout your facility.

The RTS is manufactured in a unique way that guarantees that all electrical and mechanical components are readily accessible facilitating preventative maintenance programs and repairs. Burlodge manufacturing conforms to Environment System Standards ISO 14001.

Unique Benefits and Applications.

- Heating and hot holding of foods is accomplished by using thermo-convection designed to circulate hot air throughout the oven side of the RTS. This allows for longer hot temperature holding periods. Cold food items remain refrigerated through the use of a forced air circulation system. Hot and cold food can be maintained at excellent serving temperature inside the same cart on the same service tray.
- With the RTS you can use any type of dishware such as china, high heat plastics, single use (disposables), aluminum, or high temperature paper products.
- The RTS has two doors that fold back and open allowing the operator easy and quick access to both sides of the cart, all trays and all trayed meal components (both hot and cold).
- The RTS control panel is easy to see when the doors are open or closed.
- The side panels and the top of the cart are made of ABS (Acrylonitrile-Butadiene-Styrene), a thermoplastic that is strong, long-wearing, and resistant to stains and chemicals.
- The RTS is available in four tray capacity sizes : 20, 24, 26, or 30.
- Two (2) lateral handles allow safe and easy movement of the cart by staff.
- The RTS is protected by bumpers that surround the base of the cart. The interior of the cart is welded like the exterior , using 304 34 18/10 stainless steel.
- The home style flat tray has no ridges, holes, or recesses and is reversible and stackable – available in three (3) colours – beige , orange and pastel green.
- The hidden vertical air condenser does not protrude into the interior of the cart and the evaporation of condensation is completed through air flux.
- The divider wall that helps separate the cold and hot sides of the RTS can be easily removed to facilitate cleaning. It can also be removed completely and wire grids put in place to create shelving so that the cart can be used for cold holding of bulk or portioned foods.
- Options include: a guard rail on the top of the unit to support other items to service areas such as ward stocks, nourishments, and bread baskets. A breakfast tray and interior cart configuration to support continental breakfast service. A six wheel configuration to improve push/pull factors in challenging environments such as carpeted floors, slopes, and tight corridors. A tow bar to facilitate multiple cart delivery using a motorized towing system.

On One Tray - Two Different Temperatures. Single handling makes you Ready To Serve with style and ease.

Inside the Ready To Serve there is a divider wall that completely separates the hot from the cold side of the tray. You demand hot holding and cold holding of food and the RTS supplies it. Your expectations are further enhanced with your choice of tray size. You can use a large style flat tray (575mm x 325 mm) or you can use a smaller size flat tray (530mm x 325mm).

The tray slides into the divider wall in a natural way that immediately guarantees the separation of the tray components and keeps your foods at the right serving temperature. When you are ready to serve your clients, the Burlodge RTS is ready to serve you with a tray that is simply removed in one motion and presented with a smile.





The Ready To Serve Burlodge Difference

Attractive tray presentation without clutter.

The Burlodge home style flat tray can be personalised to your needs (a large tray or a small tray). Furthermore, the surface area of the tray and the methods of heating and cooling provide each food service expert an opportunity to create a complete meal that is pleasing to see, easy to enjoy, and tempting to each individual and their specific need.



A flexible solution for every requirement

Simplicity of operation.

The RTS takes care of keeping food hot and foods cold. It is easy to use. Staff are trained quickly and are rewarded when their clients receive hot foods hot and cold foods cold. The two (2) doors allow simplified maintenance and ease of accessibility.



Respect for hygiene and safe food handling.

The divider wall can easily be removed for washing and sanitizing at any time. As an accessory, a removable clearing shelf can be installed which also houses a garbage bag holder.



Simplistic control panel with ready to program functions.

- On and Off touch pads
- Three temperature holding cycles with programming of the hot and cold sides of the RTS
- Alternate reading of the temperatures in the hot and cold cavities of the cart
- Automatic timer (the RTS comes on when you program it to)
- Audible alarm at the end of a cycle
- Ventilation cycle
- Transmission of data for HACCP tracking.



Personalisation of trays.

Patient trays can be further personalised and enhanced by the use of high quality china. A wide assortment of shapes and sizes with attractive reusable lids is available to co-ordinate with all your menu needs. Burlodge China is available in three colours and classic white.



RTS

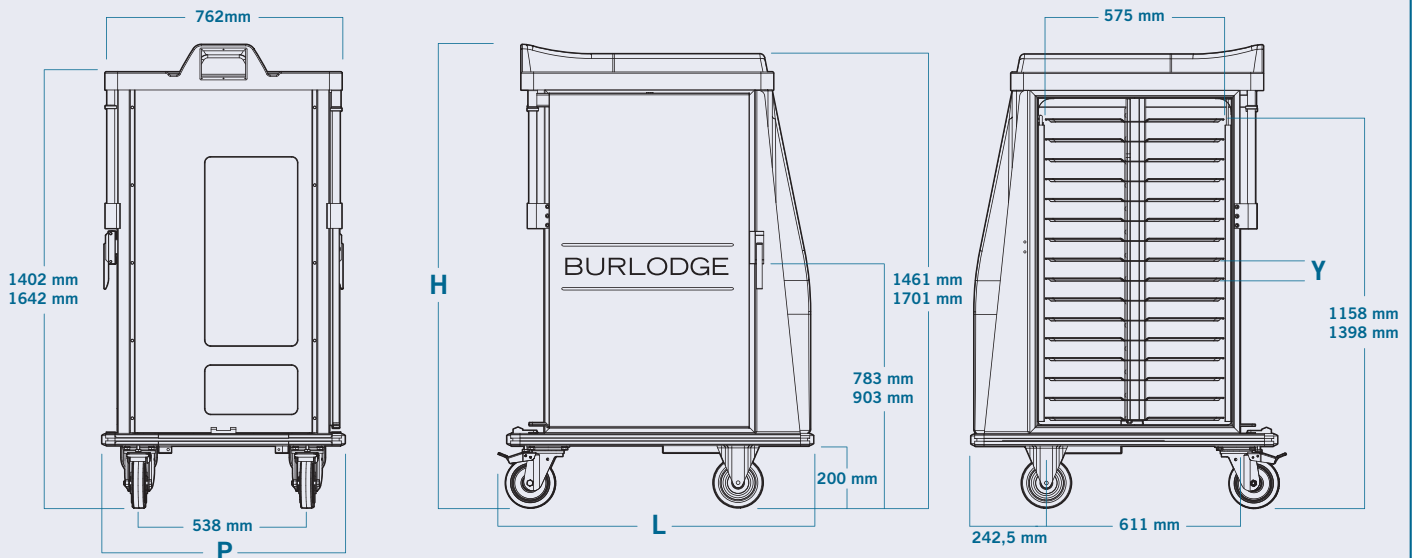

RTS Ready To Serve

REF.	DESCRIPTION	Tray Pitch Y mm/inch	ELECTRICAL SPECIFICATIONS				DIMENSIONS		
			Total		Refrigeration only		H mm/inch	L mm/inch	P mm/inch
			AMPS	MAX kW	AMPS	kW			
BLS3S.500	RTS short with integrated single refrigeration - single phase - 208V - 60 Hz - 2P+G	80/92 3,15/3,62	16	3,1	5,0	1,0	1.482 58,35	986 38,82	778 30,63
BLS3S.700	RTS short with integrated single refrigeration - three phases - 208V - 60 Hz - 3P+G	80/92 3,15/3,62	20	6,2	5,0	1,0	1.482 58,35	986 38,82	778 30,63
BLS3T.500	RTS Tall with integrated single refrigeration - single phase - 208V - 60 Hz - 2P+G	80/92 3,15/3,62	16	3,1	5,0	1,0	1.722 67,80	986 38,82	778 30,63
BLS3T.700	RTS Tall with integrated single refrigeration - three phases - 208V - 60 Hz - 3P+G	80/92 3,15/3,62	20	6,2	5,0	1,0	1.722 67,80	986 38,82	778 30,63

Trays

REFERENCE	DESCRIPTION	DIMENSIONS
		L x P mm/inch
BLS00.000._	01 RTS Single Tray Beige	575 x 325 22,64 x 12,80
	02 RTS Single Tray Pastel green	
	03 RTS Single Tray Pastel orange	
BLS00.000._	30 RTS Single Tray Beige	530 x 325 20,87 x 12,80
	32 RTS Single Tray Pastel green	
	34 RTS Single Tray Pastel orange	

Accessories

REF.	DESCRIPTION
BLS0A.300	Top barrier
BLS0A.320	Lateral shelf
BLS0A.340	Ward destination holder
BLS0A.380	Tow Bar
BLS0A.480	Locking device with key

AZIENDA CON SISTEMA DI GESTIONE
PER LA QUALITÀ CERTIFICATO DA DNV
= UNI EN ISO 9001:2008 =

BURLODGE™



BURLODGE SRL
Via Ca' Bertoncina, 43
24068 Seriate BERGAMO
ITALY
Phone +39 035 4524900
Fax +39 035 302.994
Internet www.burlodge.com
E-mail info@burlodge.it

BURLODGE LTD
Unit 5 Hook Rise, Business Centre
225 Hook Rise South - SURBITON
Surrey KT6 7LD - UNITED KINGDOM
Phone +44 020 8879.5700
Fax +44 020 8879.5701
Internet www.burlodge.com
E-mail sales@burlodge.co.uk

BURLODGE SA
40 Boulevard de Nesles
77420 Champs sur Marne
FRANCE
Phone +33 01 60 17 66 74
Fax +33 01 64 11 43 10
Internet www.burlodge.com
E-mail accueil@burlodge.fr

BURLODGE USA Inc.
P.O. Box 4088, 3760 Industrial Dr.
Winston - Salem 27115 - 4088
North Carolina - USA
Phone 001 336 7761010
Fax 001 336 7761090
Internet www.burlodge.com
E-mail info@burlodgeusa.com

BURLODGE CANADA LTD
10, Edvac Drive,
BRAMPTON Ontario L6S 5P2 - CANADA
Bureau au Québec (514) 339-5552
Tel. 001 905 790.1881
Fax 001 905 790.1883
Internet www.burlodge.com
E-mail info@burlodgeca.com